

AXMINSTER

Hobby
SERIES

Code 102266

HBS200N 200mm Bandsaw



AT&M: 24/04/2017
REF: 102667

Index of Contents

Index of Contents	02
Declaration of Conformity	02
What's Included	03-04
General Instructions for 230V Machines	05-06
Specification	06
Assembly	06-07-08
Illustration and Parts Description	09-10-11-12-13
Setting Up the Saw	14-15-16-17
Operating Instructions	17-18
Changing the Saw Blade	18-19
Routine Maintenance	20
Machine Footprint	21
Bandsaw Blade Information	22-23
HBS200N Hobby Bandsaw Blades	24
Bandsaw Trouble Shooting/Accessories	24
UJK Technology Bandsaw Buddy	25
Parts Breakdown/List	26-27-28
Wiring Diagram	29
CE Certificate	30
Notes	31

Declaration of Conformity

Copied from CE Certificate

Authorised by Laiszhou Fulin Machinery Co., Ltd
Wengchang Road Street, Nanwuli Industry Yard
Laizhou, Shandong 261400, P.R.CHINA

BM registration No: 50339084

Report No: 17700109 004

Model Number: BS200 (Band Saw)

Manufactured by Laiszhou Fulin Machinery Co., Ltd is in compliance with the standards determined in the Council Directive.



Warning

The symbols below advise that you follow the correct safety procedures when using this machine.



Fully read manual and safety instructions before use



Ear protection should be worn



Eye protection should be worn



Dust mask should be worn



HAZARD
Motor gets hot

What's Included

Quantity	Item	Part	Model Number
			BS200
1 No	HBS200N 8" Bandsaw	A	
1 No	Bandsaw Blade 1,400mm Long 6" TPI (Mounted on the saw but not tensioned)		
1 No	Table	B	
1 No	Fence Rail with Scale	C	
1 No	Fence Assembly	D	
1 No	Mitre Fence (Optional Accessory)	E	Code: 102919
1 No	Push Stick	F	

Fixings

4 No	M6 x 12mm Bolts	G
4 No	M6 Shakeproof Washers	H
4 No	M8x12mm Bolts	I
4 No	M8 Washers	J
1 No	Angled Bolt and Nut	K
1 No	3mm Hex Key	L
1 No	10-13mm Spanner	M
1 No	Instruction Manual	

Having unpacked your saw (see below) and its accessories please dispose of any unwanted packaging properly. The cardboard packaging is biodegradable.



What's Included



Optional Mitre Fence
Code: 102919

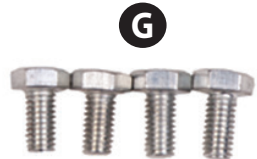

Good Working Practices/Safety

The following suggestions will enable you to observe good working practices, keep yourself and fellow workers safe and maintain your tools and equipment in good working order.



WARNING! KEEP TOOLS AND EQUIPMENT OUT OF THE REACH OF YOUNG CHILDREN

Primary Precautions

These machines are supplied with a moulded 13 Amp. plug and 3 core power cable. Before using the machine inspect the cable and the plug to make sure that neither are damaged. If any damage is visible have the tool inspected/repaired by a suitably qualified person. If it is necessary to replace the plug, it is preferable to use an 'unbreakable' type that will resist damage on site. Only use a 13 Amp plug and make sure the cable clamp is tightened securely. Fuse as required. If extension leads are to be used, carry out the same safety checks on them and ensure that they are correctly rated to safely supply the current that is required for your machine.

Work Place/Environment

Make sure when the machine is placed that it sits firmly on the floor, that it does not rock and is sufficiently clear of adjacent obstacles so that cutting operations will not be impeded. Check you have adequate clearance both in front of and behind the machine when cutting long stuff. If you are liable to be processing unwieldy or awkward work pieces, it is suggested that you consider fastening the machine down to the floor.

The machine is not designed for sub-aqua operation, do not use when or where it is liable to get wet. If the machine is set up in the open, and it starts to rain (unusual though this would be in U.K.), cover it up or move it into the dry. If the machine has got wet; dry it off as soon as possible with a cloth or paper towel. Do not use 230V a.c. powered machines anywhere within a site area that is flooded or puddled and do not trail extension cables across wet areas. Keep the machines clean; it will enable you to more easily see any damage that may have occurred. Clean the machine with a damp soapy cloth if needs be, do

not use any solvents or cleaners, as these may cause damage to any plastic parts or to the electrical components. Keep the work area as uncluttered as is practical, this includes personnel as well as material.



UNDER NO CIRCUMSTANCES SHOULD CHILDREN BE ALLOWED IN WORK AREAS.

It is good practice to leave the machine unplugged until work is about to commence, also make sure to unplug the machine when it is not in use or unattended. Always disconnect by pulling on the plug body and not the cable. Once you are ready to commence work, remove all tools used in the setting operations (if any) and place safely out of the way. Re-connect the machine.

Carry out a final "tightness" check e.g. guide fence, table tilt, etc., check that the 'cutting path' (in this case the path that the work piece will travel) is unobstructed.

Make sure you are comfortable before you start work; balanced, not reaching etc.

If the work you are carrying out is liable to generate flying grit, dust or chips wear the appropriate safety clothing, goggles, gloves, masks etc. If the work operation appears to be excessively noisy, wear ear-defenders. If you wear your hair in a long style, wearing a cap, safety helmet, hair net, even a sweatband, will minimise the possibility of your hair being caught up in the rotating parts of the tool. Likewise, consideration should be given to the removal of rings and wristwatches, if these are liable to be a 'snag' hazard. Consideration should also be given to non-slip footwear, etc.

Do not work with cutting tools of any description if you are tired, your attention is wandering or you are being subjected to distraction. A deep cut, a lost fingertip or worse; is not worth it!

Do not use this machine within the designated safety areas of flammable liquid stores or in areas where there may be volatile gases. There are very expensive, very specialised machines for working in these areas, **THIS IS NOT ONE OF THEM.**

General Instructions for 230V Machines

Check that blades are the correct type and size, are undamaged and are kept clean and sharp, this will maintain their operating performance and lessen the loading on the machine.

Above all, **OBSERVE....** make sure you know what is happening around you and **USE YOUR COMMON SENSE.**

Specification

Code	102266
Model	HBS200N
Rating	Hobby
Power	250W 230V 1ph
Blade Speed	800 m/min
Blade Length	1,400mm
Blade Width Min/Max	6-13mm
Max Width of Cut	200mm
Max Depth of Cut	80mm
Max Width of Cut with Fence	102mm
Table Size	300 x 300mm
Table Tilt	0-45°
Table Height	290mm
Wheel Diameter	200mm
Dust Extraction Outlet	40mm
Overall L x W x H	330 x 270 x 700mm
Weight	20kg

Please read the Instruction Manual prior to using your new machine; as well as the operating procedures for your new machine, there are numerous hints and tips to help you to use the machine safely and to maintain its efficiency and prolong its life.

Keep this Instruction Manual readily accessible for any others who may also be required to use the machine.

Assembly

Fitting the Table

NOTE: The table can be fitted without removing the bandsaw blade. However, if you feel safer with the blade removed, loosen the blade tensioning knob (A), see fig 01 and very carefully remove the blade. To refit the blade refer to pages 18-19 for "Changing the Saw Blade".



WARNING! WE ADVISE YOU WEAR GLOVES AS THE BLADE HAS SHARP TEETH!

Fig 01

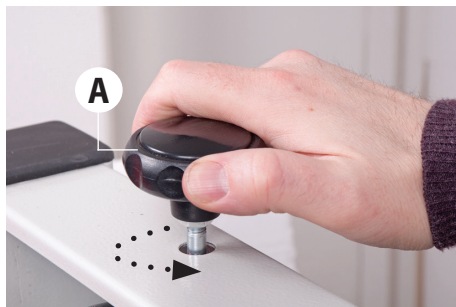

Step 1 Locate the bandsaw table (B), the four M6 bolts (G) and shake proof washers (H). Slot the blade into the table's slot and line up the threaded holes in the table with the pre-drilled holes on the tilt quadrant, see fig 02.

Fig 02

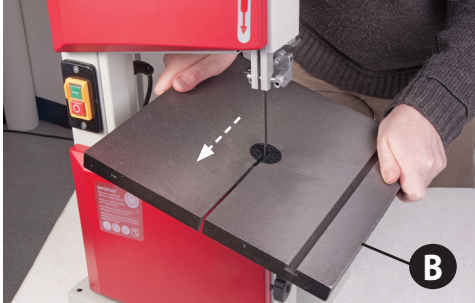

Step 2 Place a shake proof washer (H) over each M6 bolt (G), screw the bolts through the tilt quadrant into the table and tighten using the supplied spanner, see fig 03.

Fig 03



Fitting the Fence

Step 1 Locate the fence rail (C), fence assembly (D), four M8 bolts (I) and washers (J). Place a washer over the end of each bolt and lightly screw the bolts into the threaded holes beneath the front of the table (B), see fig 04. **NOTE: Leave sufficient distance between the bolt head and table for mounting the fence rail.**

Fig 04

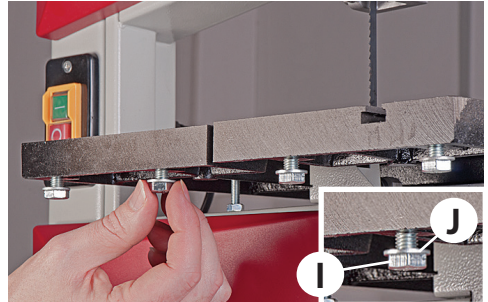

Step 2 Find the fence rail (C), line up the half moon cutouts with the four bolts in the table and insert the fence rail up against the table (B), see fig 05.

Fig 05



Secure the fence rail (C) in position by tightening the four bolts with the supplied spanner, see fig 06.

Fig 06

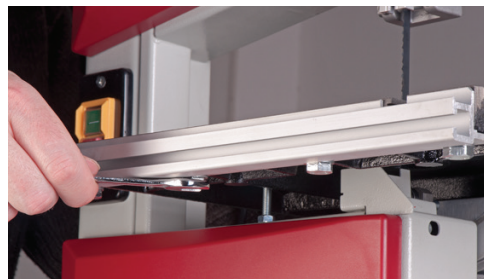

Step 3 Locate the fence assembly (D). Lower the fence over the table until the clamping lever assembly slots into the fence rail's "T" slot. **NOTE: Make sure the clamping hook to the rear of the fence (D) has engaged over the rear of the table.**

Assembly

Twist the locking lever clockwise to adjust the clamping tension.(two rotations should be adequate) then press down the lever to lock the fence in position, see figs 07-08.

Fig 07

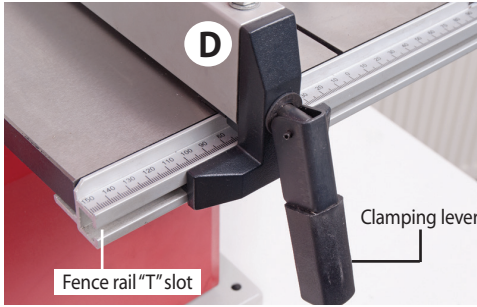

Fig 08



Step 4 Locate the angled bolt (K), screw the threaded end of the bolt into the threaded hole to the top of the bandsaw frame and, using the supplied 10mm spanner, tighten with the nut to lock the bolt in position, see fig 09. Find the push stick (F) and hook it onto the angled bolt (K), see fig 10.

Step 5 Locate the optional mitre fence assembly (E) and slide it into the table's "T" slot, see fig 11.

Fig 09-10



Fig 11

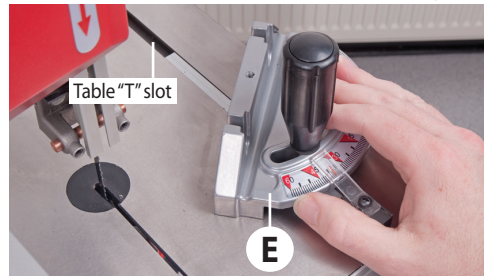

Securing the Bandsaw

Step 1 Place the bandsaw on a work bench. Mark the position of the holes in the bandsaws base, place the bandsaw to one side and drill the holes.

Step 2 Line up the holes and secure the bandsaw in place with bolts, washers and shake proof nuts.

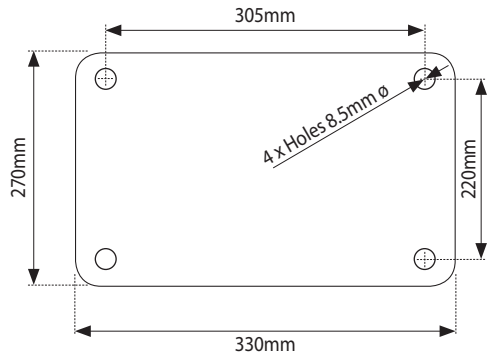
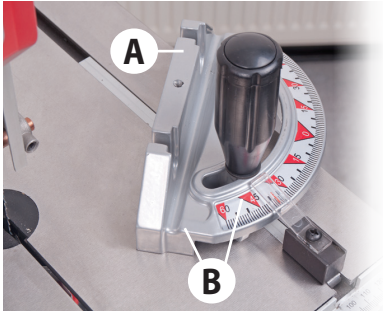

Illustration and Parts Description



Illustration and Parts Description



Optional mitre fence assembly (A)
Index and pointer (B)



Table levelling stop bolt

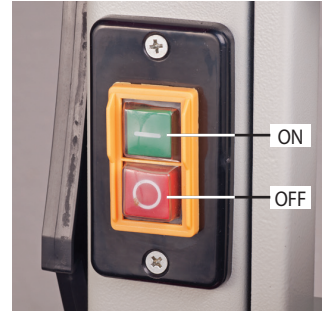

ON/OFF NVR switch assembly

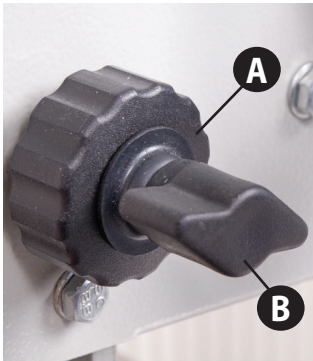

Blade guide adjusting knob (A)
Blade guide clamp (B)

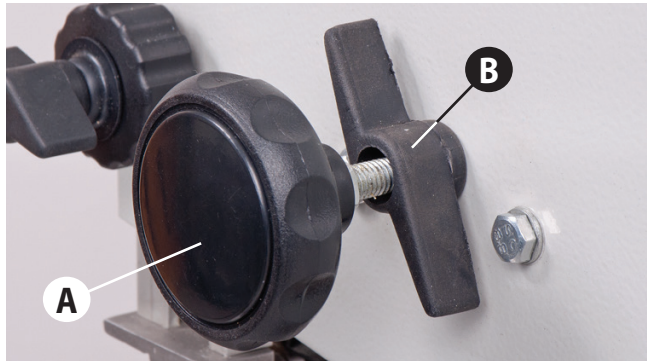

Tracking control knob (A)
Tracking control butterfly lock (B)



Blade tensioning knob

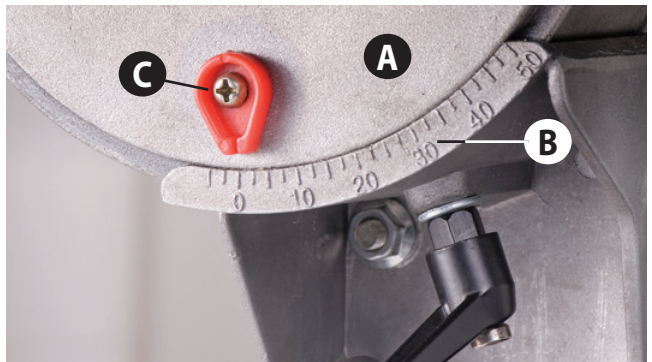

Tilt quadrant (A), Tilt scale (B)
Tilt scale pointer and adjusting screw (C)

Illustration and Parts Description

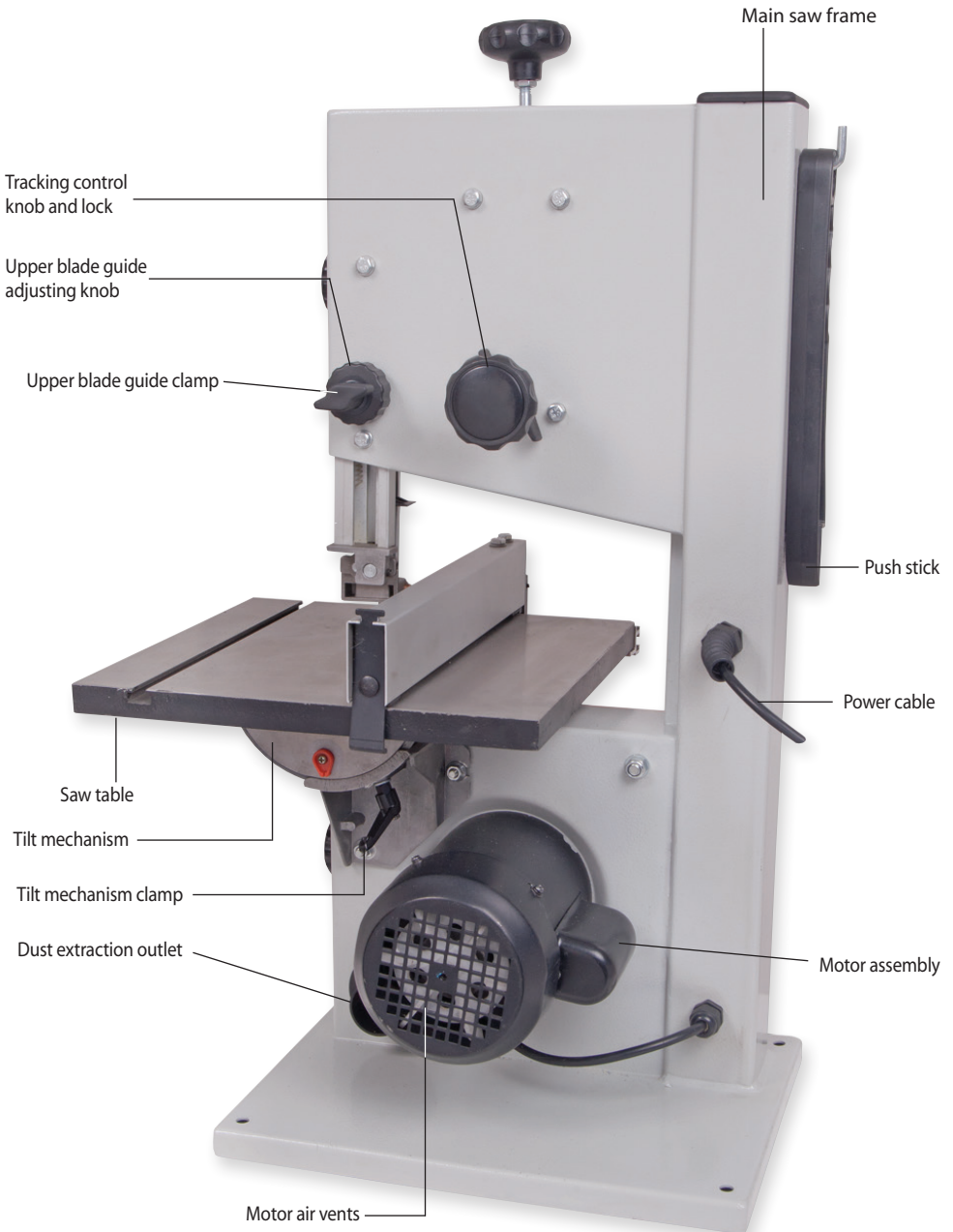
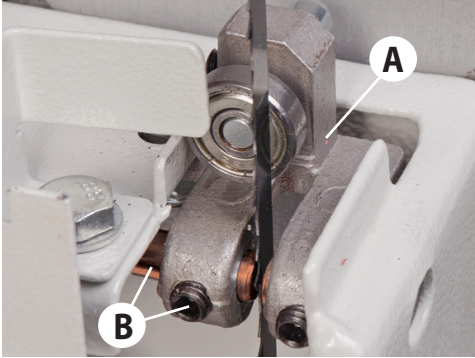
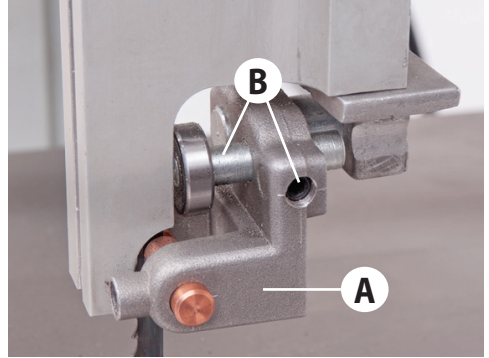

Illustration and Parts Description



Lower blade guide assembly (A)
Blade guide pin and clamping grub screw (B)



Upper blade guide assembly (A)
Rear thrust bearing and clamping grub screw (B)

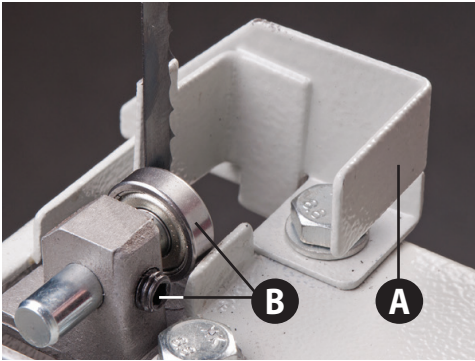

Lower blade guide guard (A)
Rear thrust bearing and clamping grub screw (B)

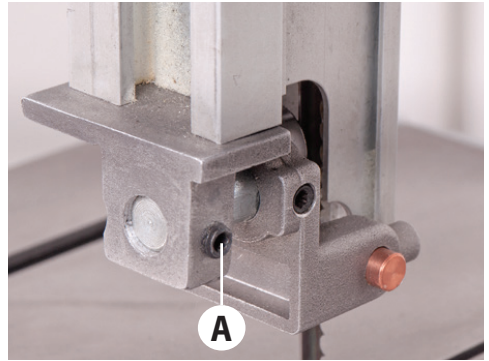

Upper guide assembly fore and aft
clamping grub screw (A)

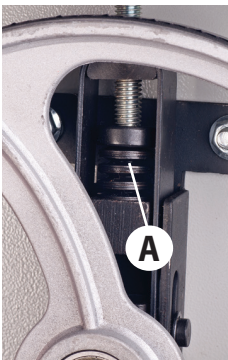

Blade tensioning spring (A),
under tension

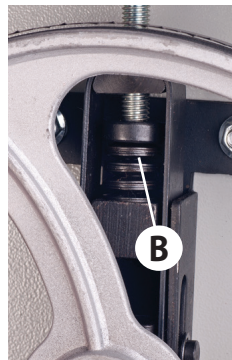

Blade tensioning spring (B)
with no tension applied

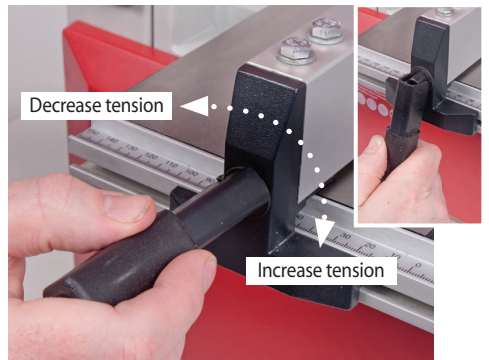

Twist the locking lever clockwise to adjust the clamping tension, (Two rotations should be adequate) then press down the lever to lock the fence in position.

Illustration and Parts Description

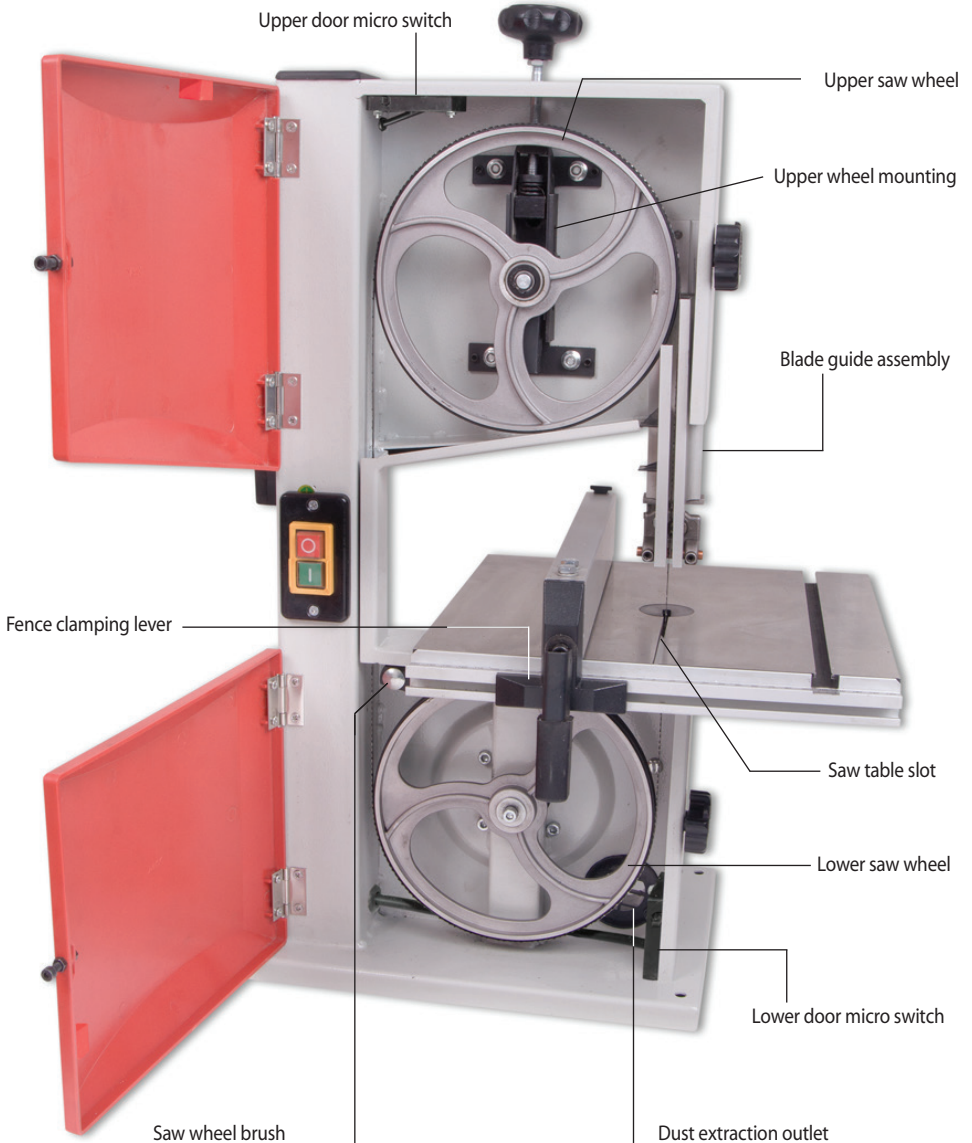

Setting Up the Saw



DISCONNECT THE SAW FROM THE MAINS SUPPLY!

Tensioning and tracking the blade

Make sure both top and bottom blade guide are well clear of the blade.

Open the front covers fully, giving good access to the top compartment of the saw and good visibility into the bottom compartment, see page 13. For tracking the blade first adjust all bearing guides so that they're well clear of the blade. Check that the blade is sitting approximately in the middle of the wheels, see fig 12.

Apply some tension to the blade by turning the tensioning wheel clockwise. Spin the top wheel by hand, and check that the blade remains centrally on the tyre, see fig 13. If it does not, loosen the tracking control lock and adjust the tracking by turning the tracking control at the rear of the upper saw wheel compartment, see fig 14. Viewed directly onto the tracking control wheel, turning clockwise should cause the blade to track to the rear of the tyre, anti-clockwise to the front (**DO NOT make large adjustments**).

Spin the top wheel again, check again. Continue until the blade tracks in the centre of the tyres with no appreciable to and fro movement. Tension the blade fully. A sideways push of about 7-8 lbs(3+kgs) in the middle of the blade should allow a 1/4" (6.5mm) distension. Check the tracking again, adjust if necessary.

Connect the power to the machine. Stand clear and start the saw, check that the saw is running smoothly, (no thumps, bumps, knocking or excessive vibration) and the blade appears to be tracking correctly (in one place). You can check this by holding a marker e.g. a pencil, close to the back of the blade (approach from the back of the blade only) and check that the gap remains constant. If it doesn't, adjust the tracking until it does. If you adjust the tracking with the saw running, make very small adjustments and wait for the saw to react before you adjust again, sometimes the reaction is not instantaneous. Once you are satisfied that the tracking is correct switch the machine off and allow it to run to a stop. Retighten the tracking control lock.

Fig 12

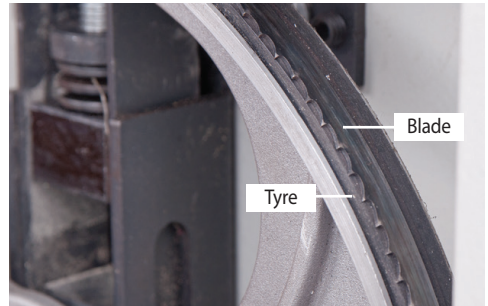

Fig 13

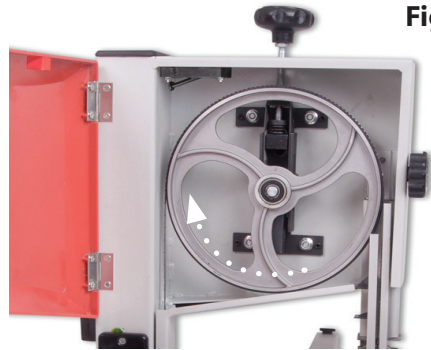
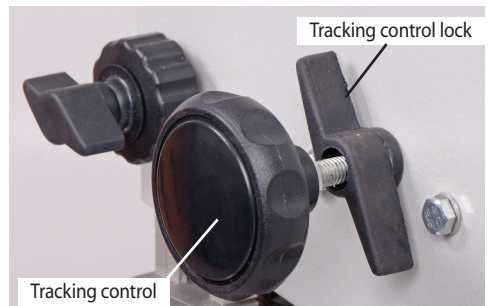

Fig 14



DISCONNECT THE SAW FROM THE MAINS SUPPLY!

Checking the table is square

If the preset table stop has been fitted, proceed as follows:-

Loosen the lift and shift handle clamping the tilt mechanism, see fig 15, and turn the table hard against its stop. This is a bolt with a lock nut screwed into the underside of the table, see fig 16, that acts as a stop when it strikes the machine frame. Tighten the butterfly nut.

Fig 15-16

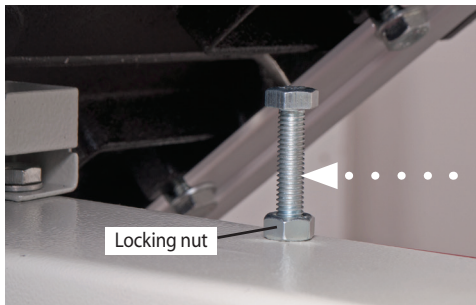
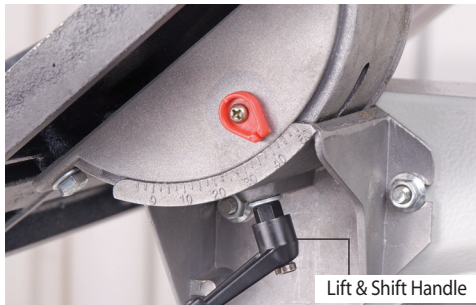

Make sure the upper blade guide is raised as high as possible. Place a square on the table and move it up against the blade (behind the teeth), see fig 17.

Fig 17

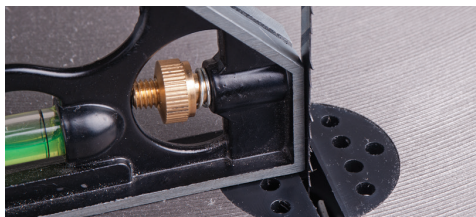

Check that the blade is perpendicular to the table. If it is not, try resetting the table.

If it is still not correct, loosen the locking nut and adjust the bolt until perpendicularity is achieved, see fig 16. Tighten the lock nut and then re-check. When you are satisfied that the table is set correctly, check that the pointer of the tilt gauge reads zero, if not, adjust it, see fig 18.

Fig 18

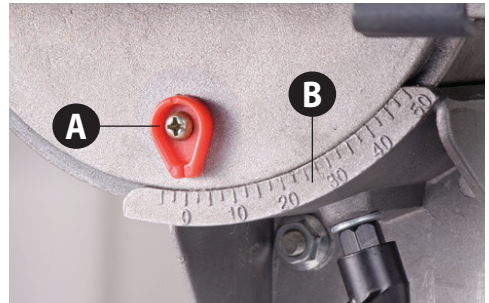

Tilt pointer (A) and tilt gauge (B)

Setting the Fence

Always make sure the fence is parallel to the table by placing an engineer's rule against the fence and setting equal distances to the front and back face of the fence, see figs 19-20.

Fig 19-20

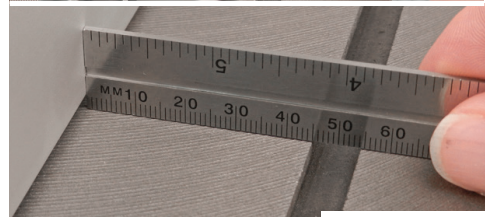
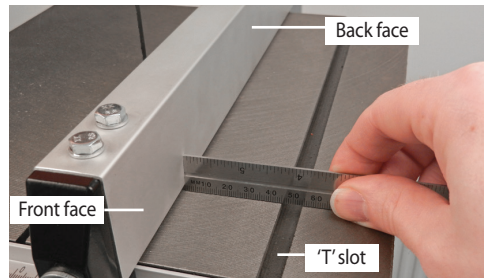

Continues Over...

Setting Up the Saw



DISCONNECT THE SAW FROM THE MAINS SUPPLY!

Setting the Blade Guides

Lower the upper blade guide to approximately 1 1/2" (38mm) above the table by loosening the blade guide height clamp and turning the adjusting knob. Clamp in place, see figs 21-22. Loosen the grub screw (A) holding the guide assembly in place, see fig 23. Adjust the fore or aft position so that the leading edges of the side guide pins are approximately 2mm behind the gullets of the saw blade. Re-tighten the grub screw, see figs 24-25.

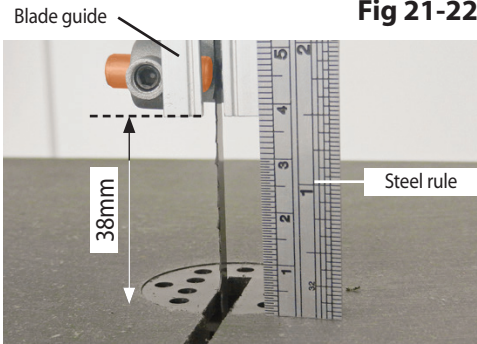

Fig 21-22

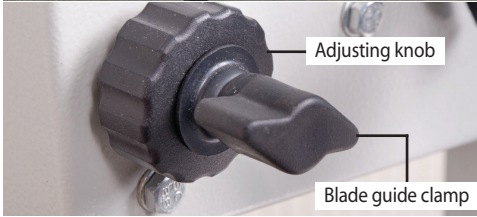

Fig 23

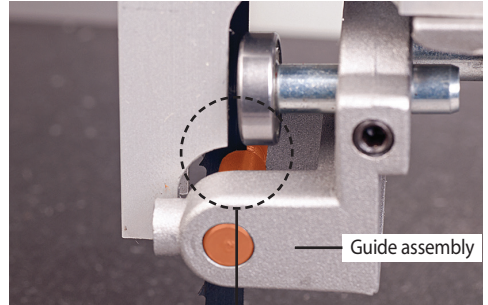
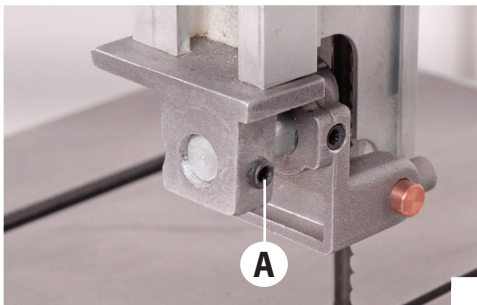

Fig 24-25

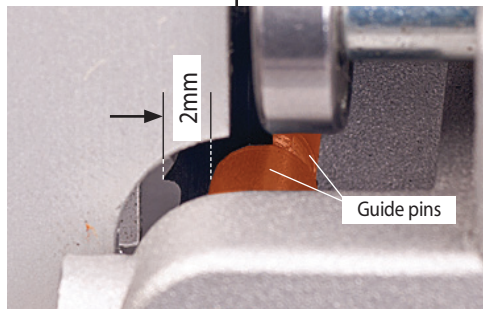
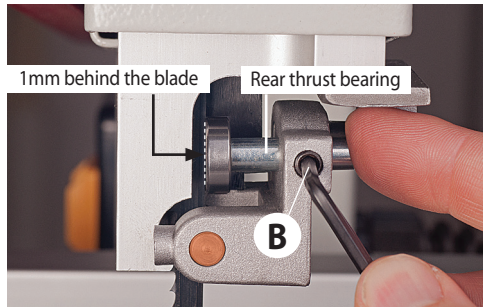
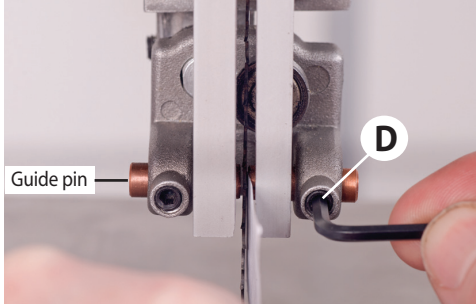

Fig 26



Loosen the grub screw (B) that clamps the rear thrust bearing and adjust the thrust bearing so it's 1mm behind the blade; re-tighten the grub screw, see fig 26. Turn the blade by hand to check the thrust bearing turns. Loosen the two grub screws holding the guide pins (D), move to approximately 0.5mm from each side of the blade. Re-tighten the grub screws. **NOTE: An A4 sheet of paper is approximately 0.5mm thick**, slide a note between the blade and guide pin until the pin is set to the correct thickness. Re-tighten the grub screws (D), see fig 27. Repeat for the other guide bush.

Fig 27



Setting the Lower Blade Guides

NOTE: For easier access to the lower blade guides it is recommended you remove the table.

Open the lower wheel access door then open the lower blade guard door, see fig 28. Repeat the procedures as described for the upper blade guides and thrust bearing, see fig 29. Once all adjustments are completed rotate the blade, replace the table and close the blade guard door.

Fig 28

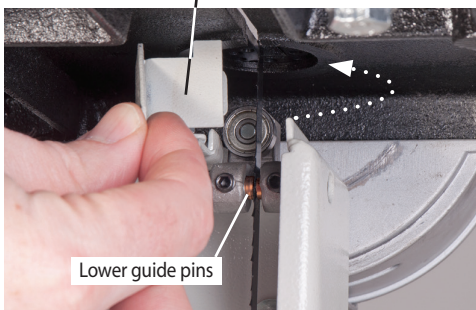
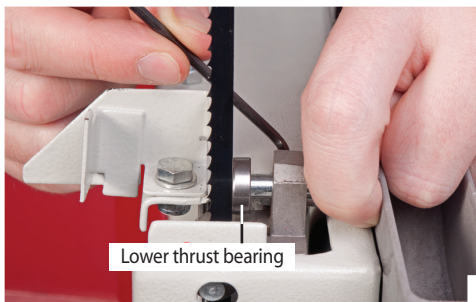

Fig 29



Close the upper and lower doors, re-connect the power, switch the saw on, allow to run for several minutes, check that the blade is still tracking correctly, there is no excessive vibration, etc. Switch off and wait until the saw comes to a complete stop. **The saw is ready to be used.**

Operating Instructions

1. Make sure you have read and fully understood the general instructions and safety precautions that are printed in the preceding pages of this manual.
2. Before connecting the machine to the supply; check the tool for obvious signs of damage, paying particular attention to the plug and the power cable. Rectify or have rectified any damage you discover. Check that the blade you are using is the correct one for the job in hand. Change the blade if necessary. Check the blade is not damaged; is clean, sharp, tracks properly and is correctly tensioned.
3. Set the upper blade guide to approximately 12mm (1/2") above the height of the work piece.
4. Check, especially on site, that there are no foreign objects e.g. old nails, screws, small stones etc. embedded in the material you are about to cut.
5. Check that all accessories, tools etc., that have been used to set the machine up, are removed and set carefully aside or stowed away correctly.
6. Ensure the machine is switched off. Plug the power cable into a correctly rated switched socket outlet. If extension leads are being used, check these for damage, do not use if damaged; if you are working outside, check that any extension cables in use are rated for outside work. Switch on. Allow the saw to run up to speed.
7. Make sure that the material you are about to cut is within the machine capacity, and the cut you are about to make is within the blade's capabilities. e.g. Do not try to cut a 1" radius curve using a 5/8" blade.
8. Make sure the blade is not in contact with the material when you start the saw. Start the cutting operation.

Operating Instructions

Do not try to cut too quickly; the correct cutting speed, if one could be so precise, would never see the blade pushed back against the thrust bearing. The saw would cut and clear the saw line at the rate the work piece was fed into it. If you notice that you require more and more pressure to effect the cut, and the blade is in continual contact with the thrust bearing, the chances are the blade is becoming blunt. Check and change if necessary.

Do not let go of the work piece; if you have to change your grip, make sure one hand is holding the material at all times.

9. If you are cutting long pieces of material think about sawing cutouts (i.e. a saw cut from the edge of the material to the saw line) along the saw line so that you can discard the off cuts as you progress down the saw line.

10. Observe the old woodworkers' adage of never allowing your hand/fingers within one handbreadth of the blade.

11. If you have to cut very small pieces of material, arrange or manufacture some form of 'shoe' to carry the timber. If the work piece is exceptionally small, find something to use as a sacrificial carrier and mount the work piece on it with double sided tape, or similar.

12. Remember to check the blade tension after a new blade has been 'working' for 30-60 mins. The blade will 'stretch' slightly when new.

13. Do not release the tension on the saw blade when work is complete. The blades and the main saw frame do not respond kindly to frequent large changes in stress and tension. Only release the tension to change the blade or if the blade is to be removed because the machine is to be 'mothballed' for a lengthy time period.

The blade in tension over a long period of non-use will cause the tyres to develop 'flat' spots. Open the saw cut, either by pulling apart or driving a wedge in close to the back of the blade. Try to "wriggle" the blade free of the saw. If this is not possible; check that the saw is free in the cut, start the saw, allow it to run up to speed and 'cut out' as quickly as possible. The removal of the 'off cut' may well prevent the saw jamming again if you resume the original cut.



**WARNING! IF THE SAW JAMS!
SWITCH OFF IMMEDIATELY.**

Changing the Saw Blade



**DISCONNECT THE SAW
FROM THE MAINS SUPPLY!**

Put the table back to the level position if it has been tilted. Set the upper blade guide assembly approximately midway in the throat. Open the top and bottom covering doors. Remove the fence and guide rail and place safely aside. Slacken the blade tension by turning the blade tensioning wheel anti-clockwise, until the blade can be easily slipped off the wheels, see fig 30.

Remove the blade carefully, "wriggling" it clear of the upper blade guard, and out through the slot in the table. NOW is an excellent time to clean out the interior of the machine, remove the impacted 'crud' from the tyres, apply a little light oil to the screw

Fig 30



Slacken the blade by turning the tensioning wheel anti-clockwise

threads of the blade tensioner, and the tracking control. The pivots and the slides of the top wheel

mounting assembly could likewise be lightly oiled. If you are fitting a new blade it will have been supplied to you “folded”; bound together in this configuration with tape or tie wrap. Also check the blade did not “unfold” inside out. i.e. looking at the right side front of the loop, the teeth should be on the front of the blade, and pointing down. If you can’t arrive at this view, turn the blade inside out from its current position and look again.



NOTE: BE VERY CAUTIOUS WHEN YOU “UNFOLD” THE BLADE; IT TENDS TO ‘SPRING’ OPEN, BLADE AND TEETH GOING EVERYWHERE.



MAKE SURE THE BLADE TEETH ARE POINTING DOWN!

Open up all blade guide pins so that they are clear of the blade. Hold the blade approximately midway on either side of the loop and feed into the table slot. When you get to the table insert cutout void, work the left side of the loop into the slot in the guard in the neck of the main saw frame. “Wriggle” the right hand side of the blade through the guard on the upper blade guide assembly. Ease the blade over the wheels and locate the blade in both the upper and

Fig 31



lower blade guides, see fig 31. Apply some tension to the blade. Turn the top wheel by hand to ensure the blade will not skip off the wheels and the blade is travelling in the blade guides, see fig 32. Apply a little more tension and check by once again spinning the

Fig 32

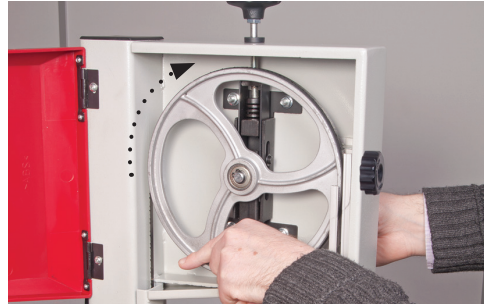

upper saw wheel by hand. Loosen the upper blade guide clamp and set the upper blade guide assembly so that the top of the blade guide is level with the centre of the top drive wheel, see fig 33. Re-tighten the clamp.

Fig 33

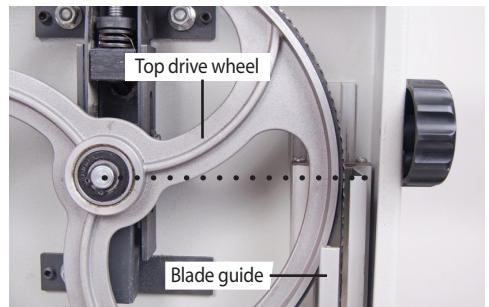

When you are sure that the blade is “ON” and stable, re-fit the fence rail and fence. Now carry out the procedures as detailed in “Setting up the Saw”.

Routine Maintenance

Daily

- Keep the machine clean.
- Check the saw blade for missing teeth and cracks, see fig 34.
- Spray oil the bare metal surfaces.

Weekly

- Open the top & bottom wheel covers and clean out all saw dust.

Clean out impacted 'crud' & saw dust



Clean out impacted 'crud' & saw dust



Monthly

- Open the lower and upper doors and check the condition of the tyres & the drive belt, see fig 34.
- Clean impacted 'crud' from the tyres, apply a little oil to the screw threads of the blade and drive belt tensioners. **DO NOT USE OIL** near the belt.
- The pivots and the slides of the top wheel mounting assembly and the captive stub axle of the belt tensioner in its slot could likewise be lightly oiled.
- Using an air line (**wearing goggles**) blow out the vents in the motor casing, see fig 35.

Fig 34

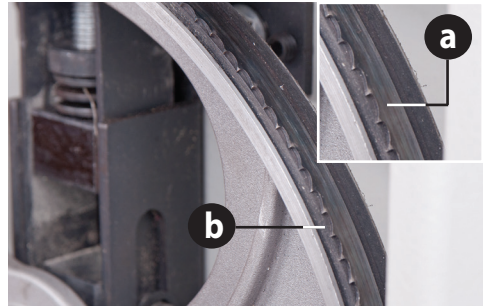
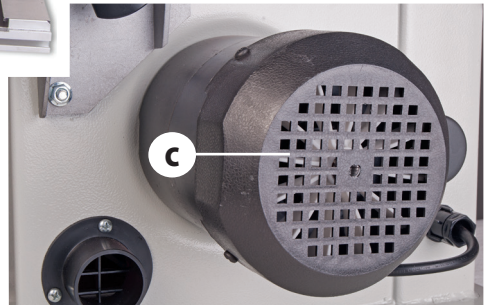
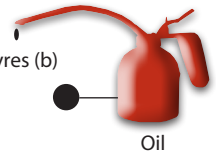
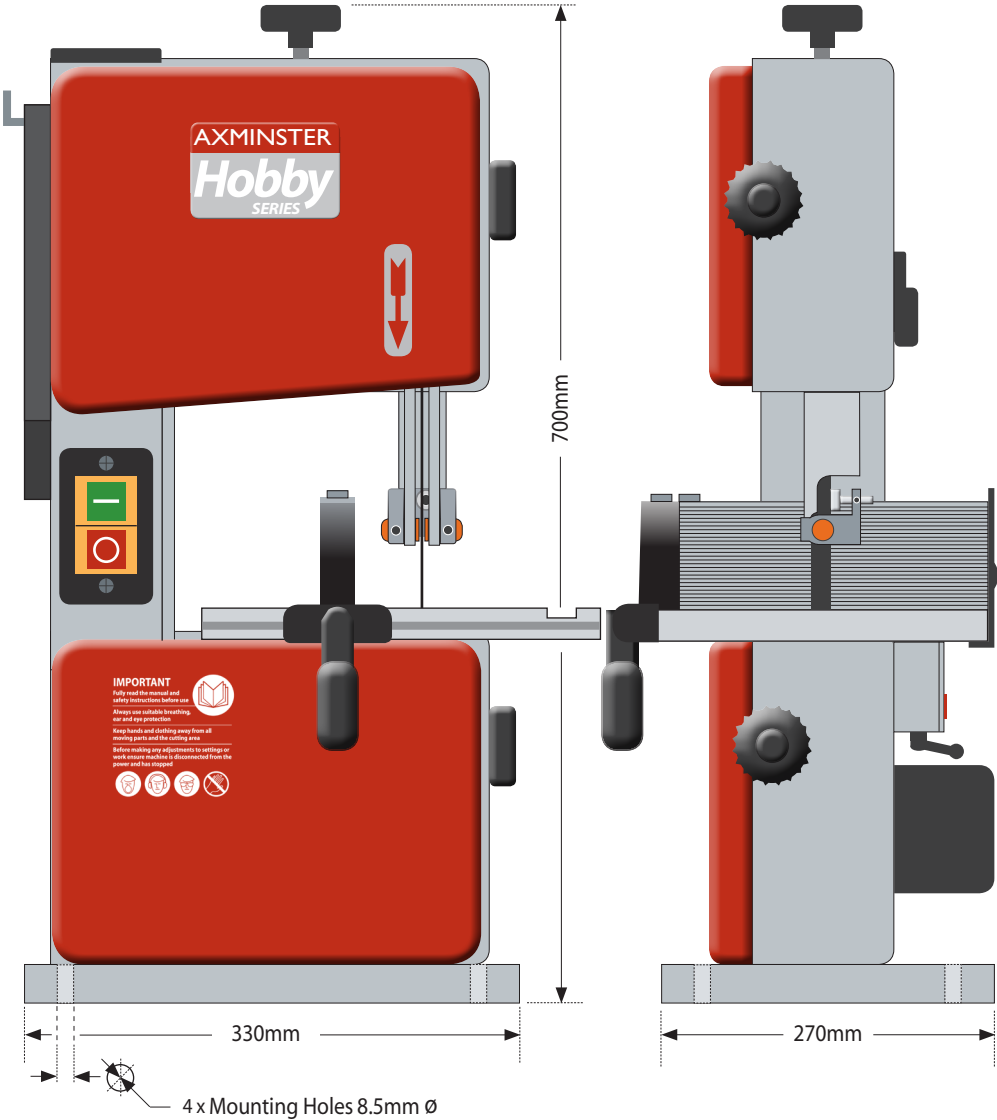

Fig 35



- Check for missing teeth (a)
- Check the condition of the tyres (b)
- Blow out motor vents (c)





Bandsaw Blade Information

About Axcaliber Bandsaw Blades

Axcaliber bandsaw blades are manufactured at Axminster using advanced CNC machining, high precision digital measuring equipment and specialised heat treatment facilities. Detailed quality checks are performed at each stage of manufacture using the most modern inspection equipment. The result is a blade which consistently cuts straighter, has harder, longer-life teeth and which gives a superior finish to the work. The final step in the manufacturing process is one of the most important; the weld. We have invested heavily in this area through the purchase of precision welding and grinding equipment and are, as a result, one of the few companies worldwide able to offer a fully guaranteed weld. Blades are cut accurately to length then, using an IDEAL bandsaw blade welder, a high voltage current is passed through the blade to achieve a precision butt weld. The weld is annealed to remove any brittleness and danger of fatigue and then hand dressed to produce a perfectly smooth joint.

Choosing the Right Tooth Pitch (tpi)

3 tpi (skip form)

Used for deep cutting especially rip cuts, this blade will leave a rough sawn finish although slow feed rate and high tension will improve the finish of the cut.



4 tpi (skip form)

Good for general-purpose use with a degree of cutting across the grain and with the grain, reasonable finish can be achieved with slower feed rates and good tension.



6 tpi (skip form)

The ideal general purpose blade suitable for cross cutting up to 150mm and ripping in sections up to 50mm thick although thicker sections can be cut using slow feed rates. This tooth form will give a clean finish and is very well suited to natural timbers.



10 tpi (regular)

Good for cutting plywood and MDF as well as non-ferrous metals and plastics. The finish is good when cutting natural timbers but the feed rate should be slow and maximum depth of cut should not exceed 50mm. When cutting metals reduce the speed as much as possible especially when cutting ferrous metals or cast iron.



14 tpi (regular)

A very clean cutting blade for plywood, plastics and MDF although too fine for natural timbers unless they are very thin sections (sub 25mm thick). The 14tpi blade is very good to use on slow speeds when cutting non-ferrous metals. A slow feed speed should be used at all times with a blade tooth pitch this fine.



Blade Width

Always use the widest saw blade possible; it is stronger and will withstand greater feed pressures without flexing. Consult your machine manual for the maximum and minimum blade widths that it will accept. The minimum radius of curve for each blade width is as follows:

Blade width	Minimum radius
13mm (1/2")	63mm (2 1/2")
10mm (3/8")	27mm (1 1/16")
6mm (1/4")	19mm (3/4")
5mm (3/16")	13mm (1/2")
3mm (1/8")	10mm (3/8")

Blade Length

This is determined by your machine model. A list of the most popular machines and their blade lengths is found in the catalogue.

Blade Tooth Form

Standard Blade Tooth Forms: We supply bandsaw blades with one of two tooth forms, skip or regular:

Bandsaw Blade Information

The skip tooth is provided on coarse tooth blades, those with 3, 4 and 6 teeth per inch; it has a wide shallow gullet with plenty of space for waste to collect. Please note that the quality of the cut can be adversely affected by sawdust packing between the teeth.

The regular, or triangular, tooth form is provided on blades with 10 or more teeth per inch where, because of the reduced material removal, there is less need for waste storage.

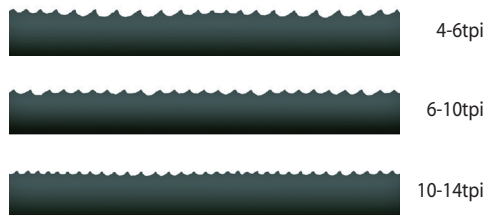

Premium Bandsaw Blades

- Premium blades made from M42 with 8% cobalt.
- Long life with high resistance to heat, abrasion and vibration.
- Variable pitch teeth for wider ranging applications.
- Also used for cutting metal on horizontal bandsaws. Blades are available in three variable pitch forms 4-6tpi, 6-10tpi and 10-14tpi.



High Carbon Bandsaw Blades

- General purpose range of blades for wood and metal cutting.
- Comprehensive range of lengths widths and tooth configuration.
- Hardened and long lasting teeth.



Ground Tooth Bandsaw Blades

- Diamond ground teeth staying sharper for at least 30% longer.
- Smoother cut over general purpose milled tooth blades.
- Comprehensive range of lengths, widths and tooth configuration.



Back Tooth Bandsaw Blades

- Specifically designed for curve cutting so ideal for wood turners.
- Back tooth design allows better clearance and tighter curves.

- Available in one width of 5/16" (8mm) x 4 tpi.

HBS200N Hobby Bandsaw Blades

Standard Axcaliber Bandsaw Blades

TPI	Width	Code
6	1/4"	508253
10	1/4"	508254
14	1/4"	508255
24	1/4"	508256
32	1/4"	508257

1,400mm(55") x 0.014"

Axminster HBS200N Bandsaw

TPI	Width	Code
4	3/8"	508258
6	3/8"	508259
10	3/8"	508260
14	3/8"	508261
6	1/2"	508262

Bandsaw Trouble Shooting/Accessories

Trouble Shooting

Bandsaws are relatively simple machines and with all machinery regular servicing (preventative maintenance) is essential to get the best from your saw.

"My bandsaw won't cut straight"

- This is the most common question that you will get from bandsaw users. Usually the answer lies within the blade; poor quality blades with uneven set, the blade is blunt or damaged often only on one side, the tooth count is far too high for the material being cut - remember 2 teeth minimum and 10 teeth maximum in the workpiece.
- The fence is out of line with the blade.

"My bandsaw vibrates"

- Clean machine wheels.
- Check blade is running correctly on wheels.
- Check blade weld – is it in line?
- Check machine is not on an uneven floor.

"My bandsaw slows down when cutting"

- Check drive belt is tensioned correctly.
- If cutting hard or wet material slow your feed rate down.
- Check blade is sharp and not too fine.
- Make sure that when curve cutting a narrow blade is used- see unit 5 blade and cutter types.

"Can I cut steel on my bandsaw?"

- No, most woodcutting bandsaws run far too fast to cut steel even if a metal cutting blade is fitted.

Accessories

Please visit our website at axminster.co.uk



Mitre Fences



Bandsaw Blades



Lubricants and Maintenance Tools

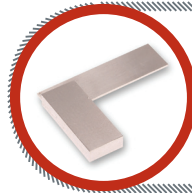

Squares



Extractors



Code: 101807

INTRODUCTION

• Bandsaw Buddy is a unique bandsaw blade aligning tool. Bandsaw Buddy allows you to check the alignment of the bandsaw blade to the face of the fence. Most other checks only require the use of a combination or engineer's square. Truing the fence to the blade is tricky. Bandsaw Buddy has two rare earth magnets which hold it firmly on the blade. At 250mm long it is easy to spot any discrepancy and then make necessary adjustments. The magnets will keep it safely stored on the bandsaw's frame when not in use.

• A scale on the tip helps set the bandsaw fence for cutting veneers or thin boards. Holes along the Buddy's length at 12.5mm intervals allow you to draw arcs or circles in 25mm steps from 75mm to 400mm, a useful feature for marking curves or when cutting bowl blanks. Accurately machined from anodised aluminium, it also makes a handy straight edge.

KEY FEATURES

- Designed and made in Axminster
- Unique bandsaw blade aligning tool
- Checks the alignment of blade to the face of the fence
- Rare earth magnets hold it firmly on the blade
- 250mm long makes it easy to spot any discrepancy
- Scale on the tip helps set fence for cutting veneers or thin boards
- Holes for drawing circles in 25mm steps from 75 to 400mm
- Accurately machined from anodised aluminium

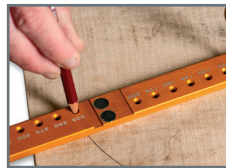
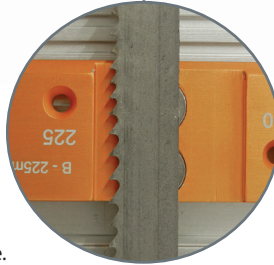
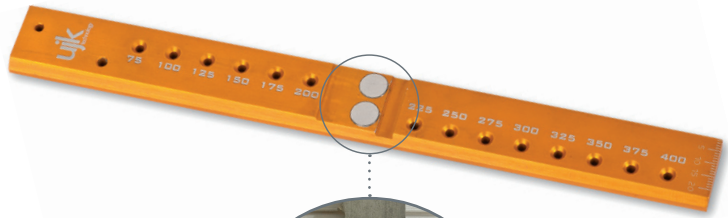

Marking Gauge

An easy to use circle marking gauge for bowl blanks from 75mm to 400mm radius in increments of 25mm.



Accurate Marking

The bandsaw buddy can be used as a straight edge for accurate marking.



Thickness Gauge

A convenient and accurate metric thickness gauge, great for veneering.



Perfect Alignment

Rare earth magnets securely hold the rule to the blade. This enables you to align your rip fence and table perfectly parallel with the blade.



Keep your buddy on hand

Once you've used your Bandsaw Buddy the integrated magnets allow simple storage on your bandsaw

Parts Breakdown/List

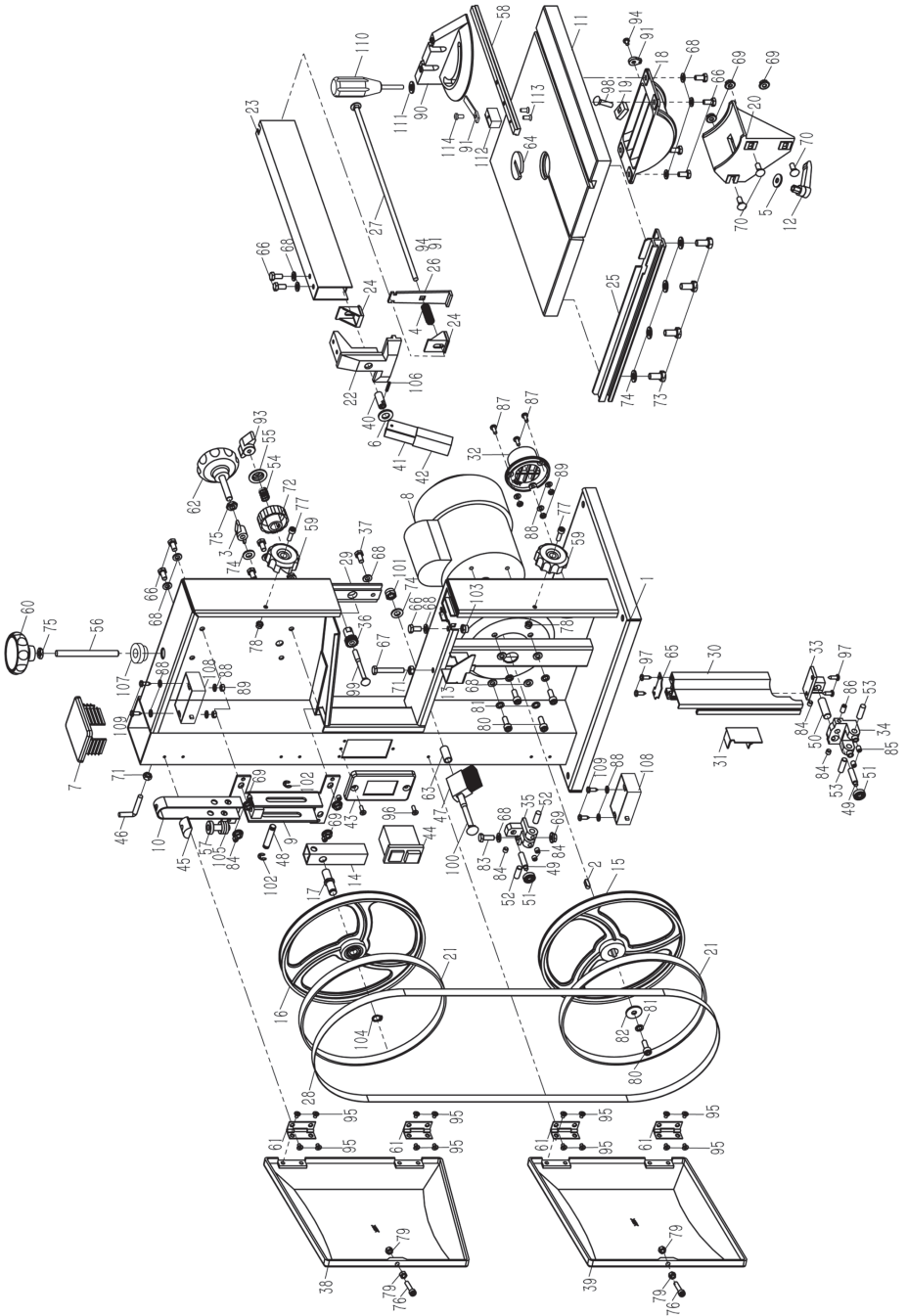

Parts Breakdown/List

PART NO	DESCRIPTION	QTY
1	Frame	1
2	Key 5x14	1
3	Wing nut M8	1
4	Spring,lock plate	1
5	Washer 6	1
6	Washer 10	1
7	Column Cover,frame	1
8	Motor	1
9	Guide bracket	1
10	Blade tensioner	1
11	worktable	1
12	Ratchet lever M6	1
13	Lower blade guide guard	1
14	Bearing bolt support upper	1
15	Lower wheel	1
16	Upper wheel	1
	Bearing 6000	2
	Circlips for holes d=26	1
17	Bearing bolt upper	1
18	Table trunnion upper	1
19	Guide piece	1
20	Worktable support	1
21	Bandsaw tyre	2
22	Locking frame for rip fence	1
23	Rip fence	1
24	Washer block	2
25	Front rail	1
26	Lock plate for rip fence	1
27	Lock rod for rip fence	1
28	Saw blade	1
29	Upper guide guard base	1
30	Upper guide guard	1
31	Slide board	1
32	Dust port	1

33	Connection seat,upper guide	1
34	Upper guide housing	1
35	Lower guide housing	1
36	Adjusting gear	1
37	Hex.bolt	2
38	Upper door	1
39	Upper door	1
40	Locking nut	1
41	Locking handle	1
42	Locking handle housing	1
43	Switch plate	1
44	Switch	1
45	Adjusting nut	1
46	Push stick hook	1
47	Brush	1
48	Pin guide	1
49	Bearing shaft	2
50	Connection shaft for upper guide	1
51	Bearing 625Z	2
52	Shaft for lower guide	2
53	Shaft for upper guide	2
54	Spring	1
55	Dishing cover	1
56	Thread rod	1
57	Tension pin	1
58	Guide board	1
59	Knob for door	2
60	Setting knob	1
61	Door hinges	4
62	Setting knob	1
63	Spacer bushing	1
64	Table insert	1
65	Cover board	1
66	Hex.bolt M6x12	11
67	Hex.bolt M6x40	1

Parts Breakdown/List

68	Washer 6	18
69	Flange nut M6	8
70	Square neck bolt M6x16	3
71	Hex.nut M6	2
72	Adjusting knob	1
73	Hex.bolt M8x16	4
74	Washer 8	6
75	Thin hex.nut M8	2
76	Hex.socket cap head screw M5x25	2
77	Hex.socket cap head screw M5x16	2
78	Self-lock nut M5	2
79	Hex.nut M5	4
80	Hex.socket cap head screw M6x16	5
81	Spring washer 6	5
82	Large washer 6	1
83	Hex.bolt m6x16	1
84	Hex.socket set screw M6x6	9
85	Hex.socket set screw M6x8	2
86	Hex.socket set screw M6x12	1
87	Cross recessed pan head screw M4x10	3
88	Washer 4	9
89	Hex.nut M4	5
90	Mitre gauge	1
91	Pointer,mitre gauge	2
93	Knob	1
94	Cross recessed pan head screw M4x6	1

95	Cross recessed countersunk screw M4x6	16
96	Cross recessed countersunk screw M4x12	2
97	Cross recessed pan head tapping screw ST4.2x12	4
98	Square neck bolt M6x25	1
99	Square neck bolt M6x60	1
100	Square neck bolt M8x70	1
101	Self-lock nut M8	1
102	Split washer 6	2
103	Self-lock nut M6	1
104	Circlips for shaft d=26	1
105	Saddle washer	7
106	Spring-type pin 3x16	1
107	Step bushing	1
108	Safety switch assembly	2
109	Cross recessed pan head screw M4x30	4
110	Mitre gauge knob	1
111	Washer 6	1
112	Mitre gauge block	1
113	Cross recessed countersunk screw M5x12	2
114	Cross recessed pan head screw M5x10	1

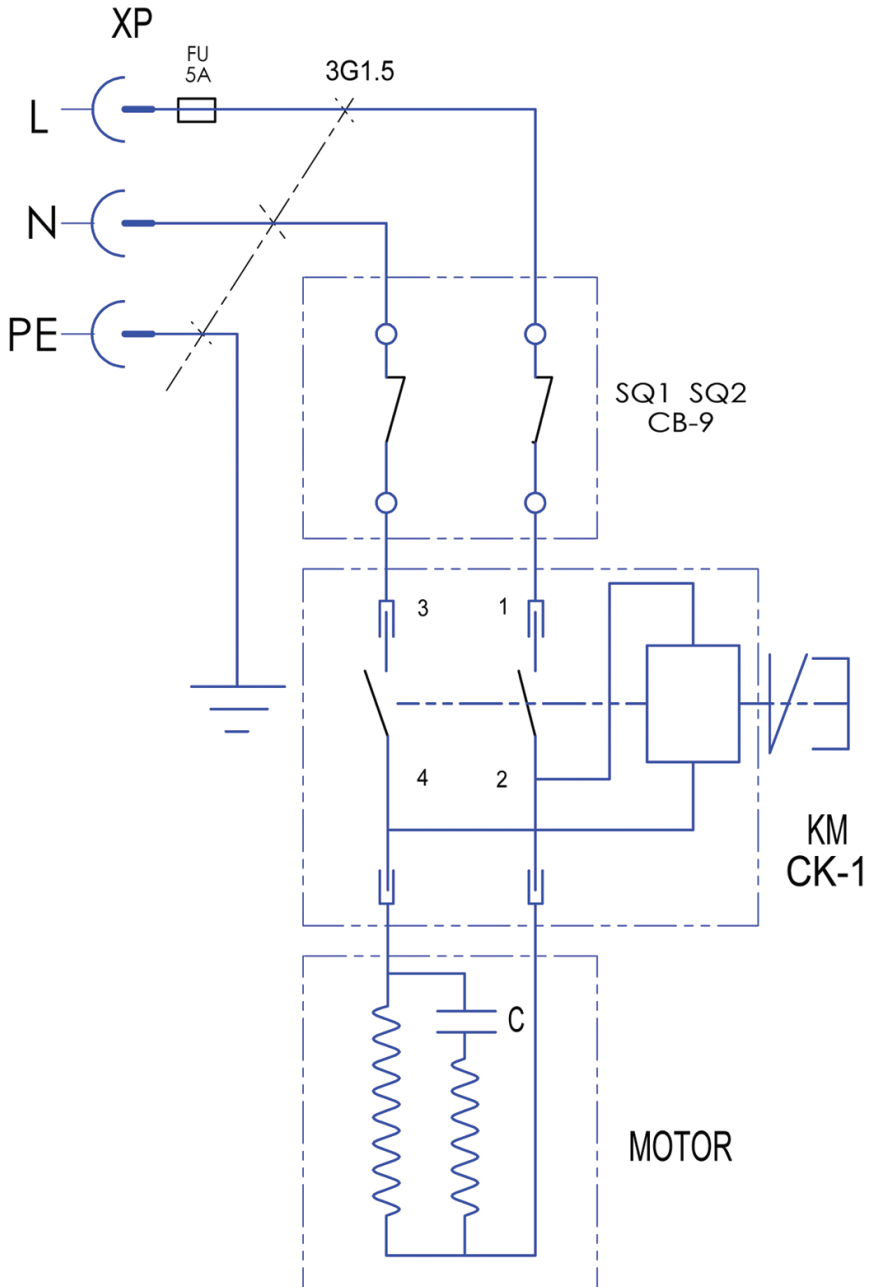



C E R T I F I C A T E

for EC-Type Examination
 EC Directive 2006/42/EC Article 12, Section 3b
 Machinery

Registration No.: **BM 50339084 0001**

Report No.: **17700109 004**

Holder: Laizhou Fulin Machinery
 Co., Ltd.
 Wenchang Road Street
 Nanwuli Industry Yard
 Laizhou, Shandong261400
 P.R. China

Product: Band Saw
 (Band Saw)

Identification:

Type Designation:	MJ343B	MJ343B-1	MJ343B-2	MJ3435
	MJ343C	MJ343C-1	MJ343C-2	MJ3420
	MJ3425	MJ3425N	MJ3442	MJ3448
Serial No.	: FL2016001	FL2016002	FL2016003	FL2016004
	FL2016005	FL2016006	FL2016007	FL2016008
	FL2016009	FL2016010	FL2016011	FL2016012
Rated Voltage	: AC 230V, 50Hz			
Protection Class:	: I			

This product is in conformity with all requirements of Annex I of Council Directive 2006/42/EC.

This EC-type Examination Certificate refers to an evaluation of the above mentioned product as stipulated in Annex IX and documented in the a.m. Technical Report. It does not imply an assessment of the whole production and does not permit the use of a mark of conformity of TÜV Rheinland. The holder of certificate is authorized to use this EC-Type Examination Certificate in connection with the EC-declaration of conformity according to Annex II of the Directive.

Valid till: 27.06.2021

Date 28.06.2016



TÜV Rheinland LGA Products GmbH - Tillystraße 2 - 90431 Nürnberg
 Accredited by Zentralstelle der Länder für Sicherheitstechnik (ZLS).

Notified under No. **0197** to the EC Commission.

Ⓒ The CE marking may be used if all relevant and effective EC Directives are complied with. Ⓒ

The **Axminster guarantee** is available on Hobby, Trade, Industrial, Engineer, Air Tool & CNC Technology Series machines

It's probably the most comprehensive FREE guarantee ever- buy with confidence from Axminster!
So sure are we of the quality, we cover all parts and labour free of charge for three years!

- **Look for the icon and put your trust in Axminster**
- **No registration necessary - just keep your proof of purchase**
- **Optional Service Plan for Industrial Series machinery**



Great value & easy-to-use,
perfect for use at home



Solid, reliable machines
designed for daily use



Top performers with class leading features and
build quality for use in busy workshops



Quality, precision machines
for the workshop or education



Small machines for the home
engineer



Tools for home or workshop
use; durable and great value



Precision CNC machines for
industry and education

Free Three Year Guarantee on Axminster Hobby, Trade and Industrial Series
woodworking and engineering machines, Axminster Air compressors and Air
Tools, and bench top grinders - no registration necessary just proof of purchase.

We will repair or replace at our discretion and will collect only from a UK
mainland address, irrespective of the original delivery address.

The Guarantee assumes that you have bought the correct machine for the
required operation, in accordance with our guidelines; have operated and
maintained it in accordance with the instruction manual; and that all cutting
machines will be used with a blade which is sharp and serviceable at all times.
It does not cover consumable items purchased with the original product,
including original blades or abrasives.

Normal wear and tear, misuse, abuse and neglect are excluded and the machine
should not have been modified in any way. Please do not attempt to service the
product without first contacting us; we are happy to guide you but failure to do
so may invalidate the guarantee.

The Guarantee is transferable from owner to owner in the first three years but
you must have original proof of purchase. Should we need to replace a machine
in the first three years the guarantee will still continue to be effective from the
original purchase date.

Full Terms and Conditions can be found at axminster.co.uk/terms

This guarantee does not affect your statutory rights.

For more information visit axminster.co.uk/3years



Please dispose of packaging for the product in a responsible manner. It is suitable for recycling.
Help to protect the environment, take the packaging to the local recycling centre and place into
the appropriate recycling bin.

Only for EU countries



Do not dispose of electric tools together with household waste material. In observance of
European Directive 2002/96/EC on waste electrical and electronic equipment and its
implementation in accordance with national law, electric tools that have reached the end of their
life must be collected separately and returned to an environmentally compatible recycling facility.

Axminster Tools & Machinery Ltd
Weycroft Avenue, Axminster, Devon EX13 5PH

axminster.co.uk